

FLEXIBLE CURTAIN BARRIER SYSTEM

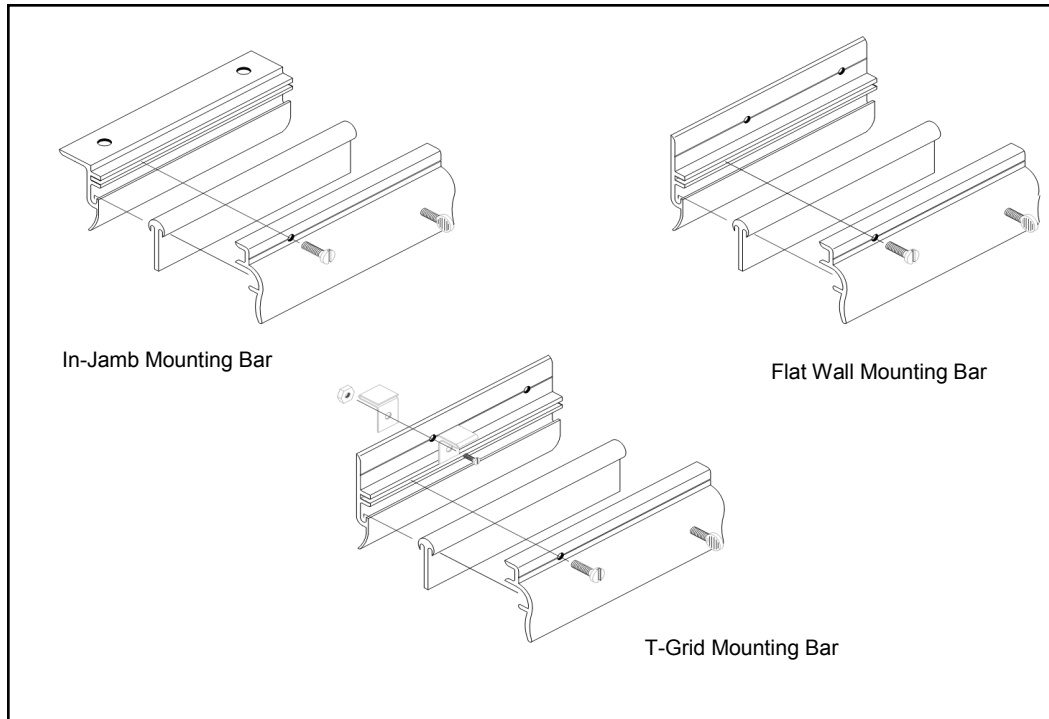

CBS SERIES

Isolation Systems, Inc.'s premiere flexible enclosure system has been developed specifically for environmental separation. This system can be utilized to create any class of clean area from class 100,000 to class 10. The versatility of this partition system is such that its use within your clean area is only limited by imagination. Offered as our standard enclosure barrier on our soft wall systems, this product can also be configured to create hood enclosures, process separators, bench shrouds and to establish multi-class environments within the shared room area. Its unique anodized aluminum mounting track system is offered in three configurations- flat wall, in-jamb and ceiling grid clip attachment, adding further to its versatility as well as its aesthetic appeal. Our standard system is offered in 40 mil polished and anti-static treated material. Optional thicknesses of up to 120 mil are also available. This extremely adaptable enclosure system will be custom tailored to your specifications. We assure your satisfaction with this unique product.

Thank you for considering **Isolation Systems, Inc.** for your airborne contamination control needs.

STANDARD FEATURES:

- 40 mil polished clear vinyl.
- Heavy-duty clear anodized aluminum mounting track systems.
- Clear welded seams.
- Integral slide-in mounting bead.

OPTIONAL FEATURES:

- Anti-static vinyl.
- Amber tint vinyl.
- Opaque black vinyl.
- Sliding track system.
- Overlapping strip curtain configurations.
- Folding track system.
- Magnetic overlap closures.
- Weighted drape bottoms.
- Dual lock fastening system.
- Swing door configurations.

NOTES:

- This system meets or exceeds standards as specified in Fed. Std. 209 E and IES-RP-CC-002.
- **Isolation Systems, Inc.** inspection reports available upon request.
- Approval drawings available upon request.
- USDA approved.

ORDERING INFORMATION:

FOR MORE INFORMATION ON THIS SYSTEM OR TO PLACE AN ORDER, SIMPLY CALL ISOLATION SYSTEMS INC.. EACH SYSTEM SHALL BE CUSTOM DESIGNED AND TAILORED TO YOUR SPECIFICATIONS AND REQUIREMENTS.

All information herein is subject to change without notice.

all catalog dimensions are nominal.



Isolation Systems Inc.

Revised 11/2015

© copyright 2002

P.O. Box 536 Wading River NY 11792 • Phone/Fax: (888) 764-7775 • www.isolationssystemsincc.com

43